

Radial 2			Ersatzteil-Liste			Tafel 1		
Pos.	Artikel-Nr.	Bezeichnung	Pos.	Artikel-Nr.	Bezeichnung	Pos.	Artikel-Nr.	Bezeichnung
1	4HM-R12	Bürste R2 (3 Segmente)	38	4HW-A06 Z1	Scheibe E 6			
2	4KK-A23	Teller-K-Scheibe 550P	39	4HW-B06 Z1	Scheibe, groß E 6			
3	FKH-121 Z	Distanzwinkel	40	4HR-C06 Z1	Stoppmutter M6			
4	4HO-I70 Z1	Schloß-Schr. M10x110	41	4HA-Y20	Y-Lager 20			
5	4HW-A10 Z1	Scheibe E 10,5	42	4HW-D08 Z1	Scheibe, dick E 8			
6	4HW-F10 Z1	Federring M10	43	FKH-108	Fahrachse			
7	4HR-A10 Z1	Mutter M10	44	4KC-B27	Achsverkleidung R			
8	4AZ-303 Z	Flanschlager 20 (inkl. Lager)	45	4DJ-E05 Z	Distanzstück R			
9	4HA-A20	Kugellager (6004 2RS)	46	4HN-G16	Luftrad 67 4.00-4			
10	4HO-C18 Z1	6kt-Schraube M8x40	47	4KC-A39	Klemmkappe 20			
11	4HW-A08 Z1	Scheibe E 8,3	48	4HO-C45 Z1	6kt-Schraube M8x80			
13	4HR-C08 Z1	Stoppmutter M8	49	4HW-D08 Z1	Scheibe, dick E 8			
14	FKL-213	Stützradspindel R2	50	4DB-Z01 Z	Stützplatte			
15	4DA-I01 Z	Konterlasche	51	4DA-F79 Z	B-Federkonsole KH			
16	4HW-C20 Z1	Scheibe, schmal E 21	52	FKH-130 Z	Gewindeplatte			
17	4HW-A20 Z1	Scheibe E 21	53	4HW-A16 Z1	Scheibe, 17			
18	FKL-104 Z	Radführung R2						
19	4DA-H143 Z	Radschwinge R2						
20	4HO-C107 Z	6kt-Schraube M8x75						
21	4HR-D08 Z1	Stoppmutter M8, Ganzmetall						
22	4HO-C108 Z	6kt-Schraube M12x75						
23	4HR-C12 Z1	Stoppmutter M12						
24	4HO-A14 Z1	6kt-Schraube M8x20						
25	4HR-A08 Z1	Mutter M8						
26	4HN-G17	Rad 125						
27	4DM-H19	Radhülse R2						
28	FKL-118 Z	Stellflügel R2						
29	4KC-A95	Flügelschraube VA						
30	4KK-A12	Blendenring (Kunststoff)						
31	4HW-B05 Z1	Scheibe, groß E 5						
32	4HY-B04 S1	Blindniet (Al 4,8x17)						
33	FKL-101	Gehülse R2						
34	4HJ-B05 1	Quadratstopfen						
35	4HO-A13 Z1	6kt-Schraube M8x16						
36	4DA-C41 Z	Unterblech						
37	4HO-A08 Z1	6kt-Schraube M6x16						

Akku

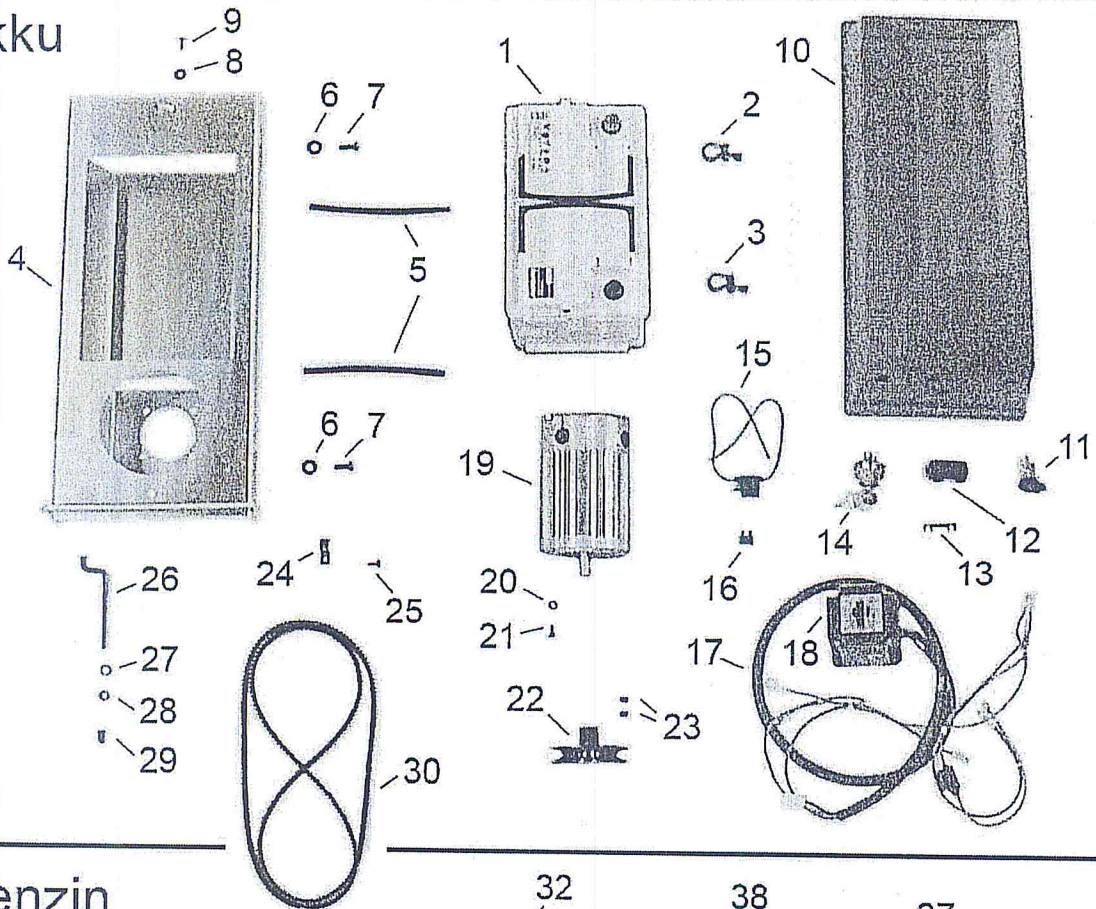

Benzin

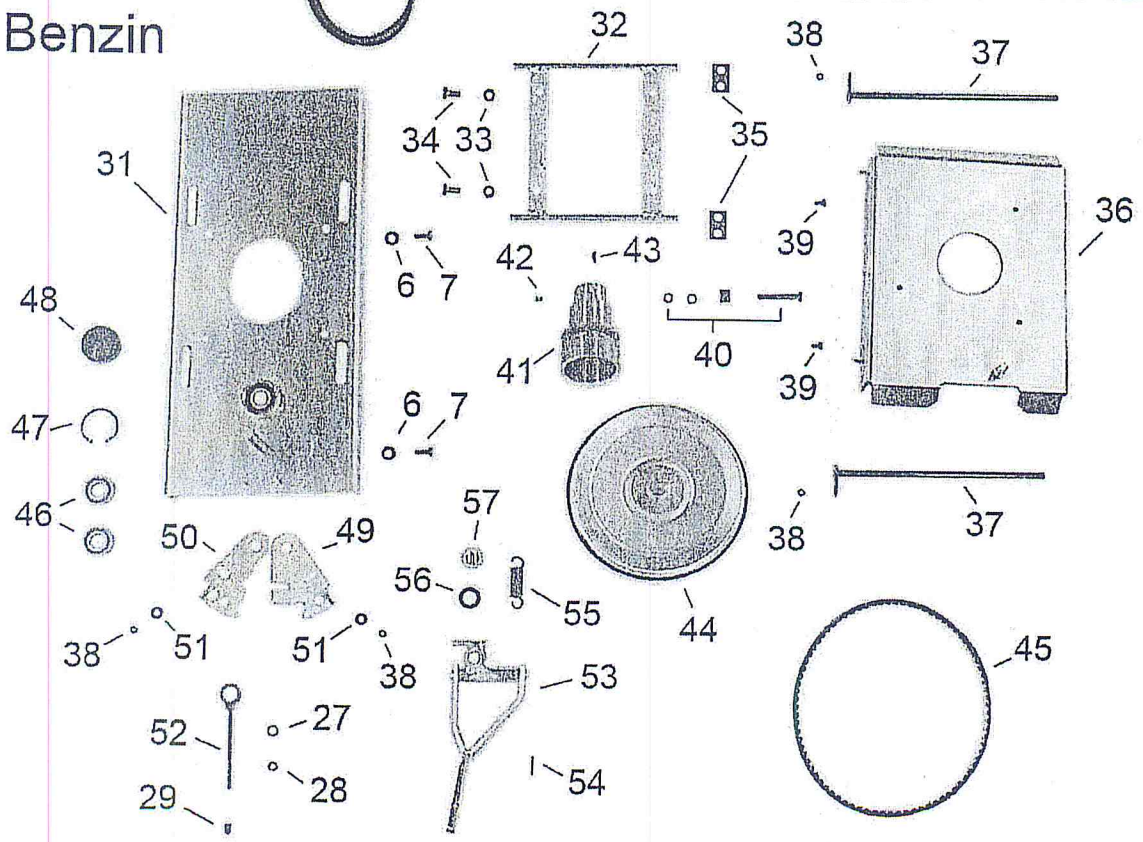

Radial 2			Ersatzteil-Liste			Tafel 2		
Pos.	Artikel-Nr.	Bezeichnung	Pos.	Artikel-Nr.	Bezeichnung			
1	4KO-B02	Spezial-R-Batterie 12V	37	FKH-110 Z	Lagerzapfen, oben			
2	4KO-S11	Polklemme +	38	4HR-C06 Z1	Stopmutter M6			
3	4KO-S12	Polklemme -	39	4HJ-B01 1	Zargenpuffer			
4	FKH-106 Z	Motorkonsole ER	40	4AZ-S22	Motorschrauben Set <small>(alle Mot.)</small>			
5	4HK-P01	Kantenschutz 16 cm	41	4AZ-A29 Z	Keilriemenscheibe RB			
6	4HW-D08 Z1	Scheibe, dick E 8,4	42	4KC-A04 1	Gewindestift M8x10			
7	4HO-A14 Z1	6kt-Schraube M8x20	43	4KH-S01	Scheibenfeder			
8	4HK-E01 1	Gummischeibe	44	FKH-209	3K-Reibrad			
9	4HO-S47 Z1	Bordwand-Schr. M8x15	45	4HB-X46 S	Keilriemen <small>(alle Benzin-Motoren)</small>			
10	4HJ-X14	Haube ER	46	4HA-A20	Kugellager 20 <small>(3004 2RS)</small>			
11	4KO-S03	Steckdose m.D.	47	4HU-I42	Sicherungsring 42			
12	4KO-A05	Sicherungshalter 50 A	48	4HJ-G06	Kappe 50			
13	4KO-A04	Blechsicherung 50 A	49	4DA-F36 Z	Stellblech, rechts			
14	4KO-S01	Schlüsselschalter	50	4DA-F35 Z	Stellblech, links			
15	4KO-A01	Hängesicherung	51	4HW-B06 Z1	Scheibe, groß E 6,5			
16	4KO-A03	FI-Stecksicherung 10A	52	FKH-111 Z	Spannschraube			
17	4KO-G36	Kabelbaum R2E2 <small>(inkl. Pos.18)</small>	53	FKL-116 Z	Schaltgelenk RB2			
18	4KO-S37	R/L-Schalter 2	54	4HX-F20 1	Spannhülse 5x20			
19	FKL-209	E-Motor ER2	55	4HI-A01 Z	Zugfeder <small>(verzinkt)</small>			
20	4HW-F06 Z1	Federring M6	56	4HW-A16 Z1	Scheibe E 17			
21	4HO-A07 Z1	6kt-Schraube M6x12	57	4KC-A41	Klemmkappe 16			
22	4AZ-Z02 Z	Keilriemenscheibe RNL						
23	4KC-A38 1	Gewindestift ZA M6x12						
24	4KC-A40 1	Kabelschelle 15						
25	4KC-A21 1	Blechschrabe						
26	4DC-D10 Z	Zugstab						
27	4HW-A08 Z1	Scheibe E 8,4						
28	4HR-C08 Z1	Stopmutter M8						
29	4HJ-G07	Kappe 8						
30	4HB-Z14 S	Keilriemen Bürste <small>(alle Mod.)</small>						
31	FKH-107 Z	Motorkonsole RB						
32	FKH-109 Z	Lagerrahmen						
33	4HR-C08 Z1	Stopmutter M8						
34	4HO-A24 Z1	6kt-Schraube M10x25						
35	4HJ-E02	Schwenklasche <small>(Kunststoff)</small>						
36	FKH-114 Z	Motorplatte RB						

